



AEROCELL SRW



The **Aerocell SRW** bridges the gap between cargo vans and cube vans. Designed exclusively for the tough, dependable, comfortable and stylish GM single rear wheel cutaway chassis, this new van body offers all of the same benefits as the original Aerocell: one piece molded fiberglass construction, seamless and glossy gel coat exterior, and aerodynamic styling. The completed vehicle has the extra height and capacity cargo vans lack, as

well as the **aesthetics, driveability** and **convenience** missing from most cube vans.

The standard package size of the competitively priced SRW makes ordering simple. The Aerocell SRW is an **ideal solution**.



- | | |
|------------------|-----------------|
| Cable | Janitorial |
| Carpenters | Locksmiths |
| Carpet Cleaners | Mobile Repairs |
| Caterers | Municipalities |
| Contractors | Painters |
| Delivery Service | Plumbers |
| Electricians | Retailers |
| Food Service | Rentals |
| Furniture | TV & Appliances |
| HVAC | Utilities |

UNICELL®

THE ONE PIECE FIBERGLASS VAN BODY

AEROCELL SRW

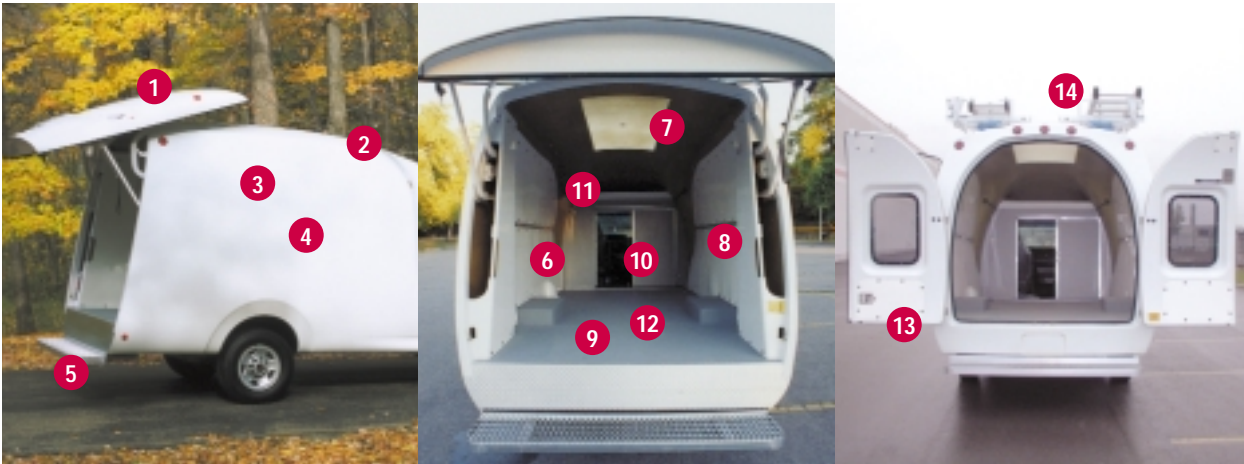

- 1 Unique easy-to-operate flip-up rear door with keyed lock and inside release handle has unrestricted load access and full height entry
- 2 Integral roof fairing and flowing body contours offer fuel-saving aerodynamics and visual appeal
- 3 The one piece molded fiberglass outer skin has no seams, rivets, or caulk, so it won't leak
- 4 The smooth glossy surface enhances your company's image-boosting graphic message
- 5 Extra deep non-skid step bumper
- 6 High density polyethylene lining is strong and brightens interior workspace
- 7 Built-in translucent skylight for a brightly lit work interior
- 8 Full length aluminum aircraft quality logistic track with adjustable tie rings and shelving attachment bolts
- 9 Tough tongue and groove plywood floor
- 10 Optional sliding access door to cab
- 11 Built-in shelf for added storage over cab
- 12 466 cubic feet of cargo space
- 13 Two-panel swing-out doors with automotive seals open to 180 degrees for easy loading. Shown with optional fixed windows
- 14 Optional roof-mounted ladder-rack with hydraulic drop-down system for easy access

NEW FEATURES!

- 13 Two-panel swing-out doors with automotive seals open to 180 degrees for easy loading. Shown with optional fixed windows
- 14 Optional roof-mounted ladder-rack with hydraulic drop-down system for easy access

DIMENSIONS

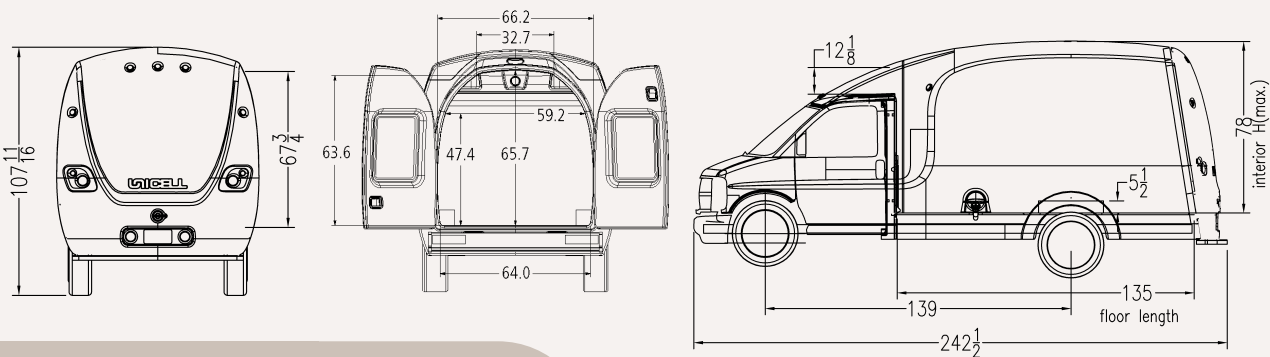

The Aerocell SRW is backed by a five-year limited warranty and our 25 years of experience in building van bodies.



50 Industrial St. • Toronto, Ontario • M4G 1Y9
Toll Free 866/905.0407 • www.unicell.com

DEL BACKS YOU UP ACROSS CANADA

VANCOUVER 1963 Kingsway Ave. Port Coquitlam, B.C. Tel 604/941.6241	CALGARY #13, 3939 - 54th Ave. Calgary, Alberta Tel 403/236.9735	EDMONTON 15618 - 111 Ave. Edmonton, Alberta Tel 780/453.7979	REGINA 1265 McDonald St. Regina, Sask. Tel 306/359.1477	BURLINGTON 2177 Plains Rd. E. Burlington, Ont. Tel 905/528.1104	TORONTO 139 Laird Drive Toronto, Ont. Tel 416/421.5851	MONTREAL 1655, boul. Hymus Dorval, Quebec Tel 514/684.1760	MONCTON 83 Caledonia Road Moncton, N.B. Tel 506/857.4291
------------------------------------------------------------------------------------	---------------------------------------------------------------------------------	------------------------------------------------------------------------------	-------------------------------------------------------------------------	---------------------------------------------------------------------------------	------------------------------------------------------------------------	----------------------------------------------------------------------------	--------------------------------------------------------------------------

Due to continuous product improvements, specifications may change without notice. Chassis available through DEL pool stock. Contact your local Chevrolet or GMC dealer for pricing.